

TECNOMEDEX - DATA SHEET

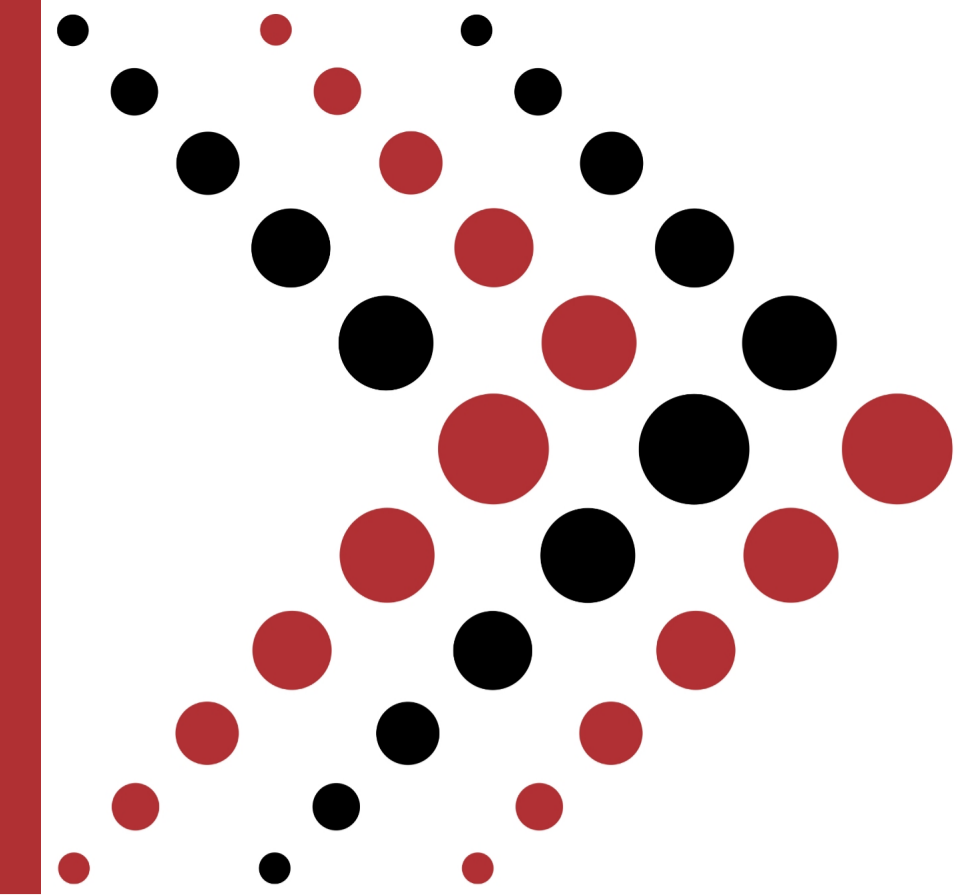

Channel Drain with Ductile Iron Grate (Slotted)

L 1000 * W 208 * H 160 mm

Code: CG-0103

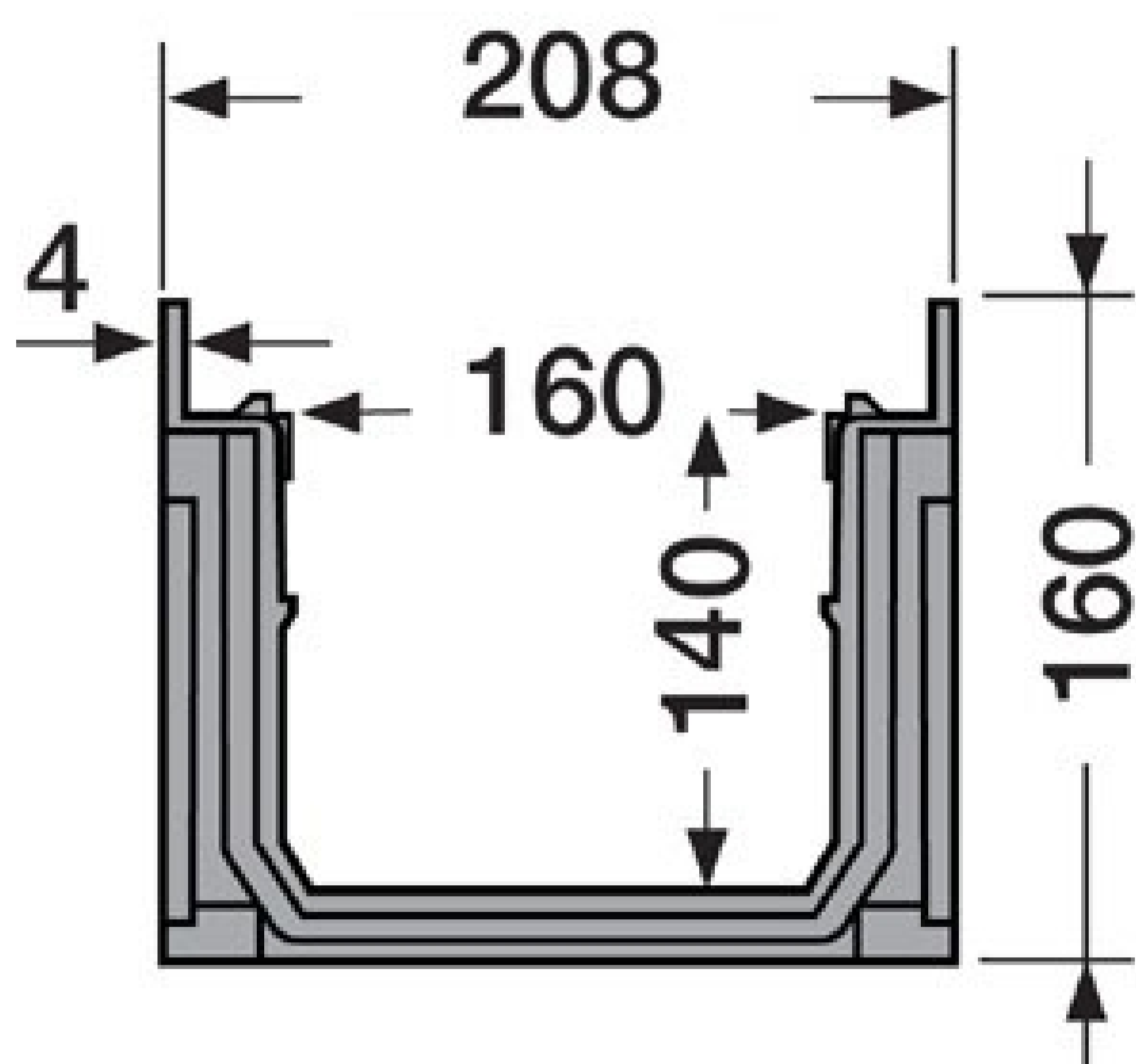

End Cap

Description

- This product is designed to drain run-off or surface water into a nearby sewage system
- Capable of cross connection (90° angle)
- Lateral or vertical outlets Ø 75, Ø 85, and Ø 110 with end caps at both ends of channel
- This product is certified in accordance with EN1433 standard and holds CE certification

Application

- Parking and ramps of residential complex and mall
- City street
- Gas station and fire station
- Industrial warehouse
- Indoor and outdoor places with high vehicle traffic



Material

- Injected Polypropylene (P.P.) and Polycarbonate channel in black color (L 1000 * W 208 * H 160 mm)
- Ductile iron grate (slotted) (L 1000 * W 200 * H 20 mm)

Technical Details

- Load class: C250
- Color: black
- Grate length is 0.5 m
- Grate type: cast iron (slotted)

Installation

See table below

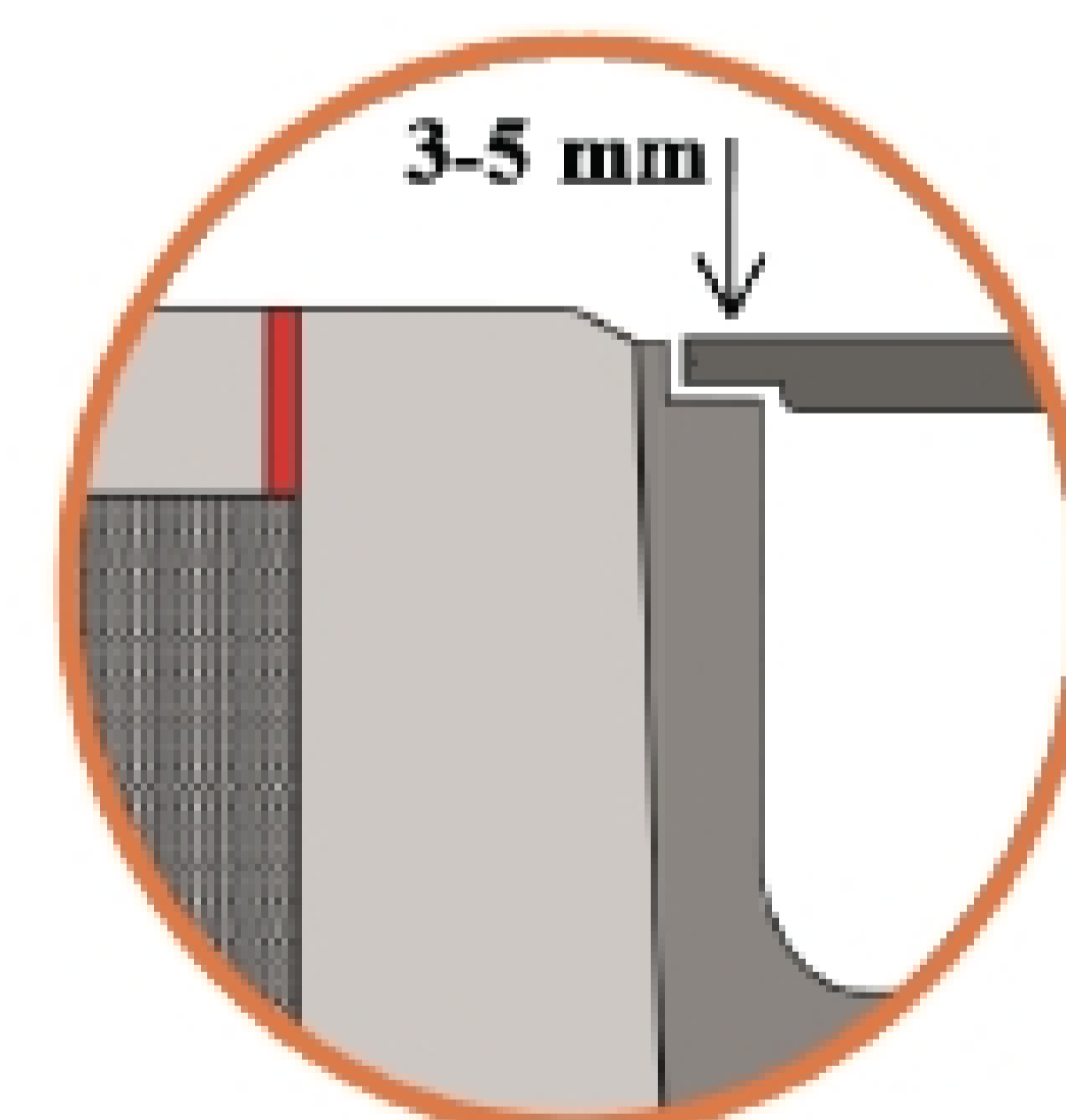
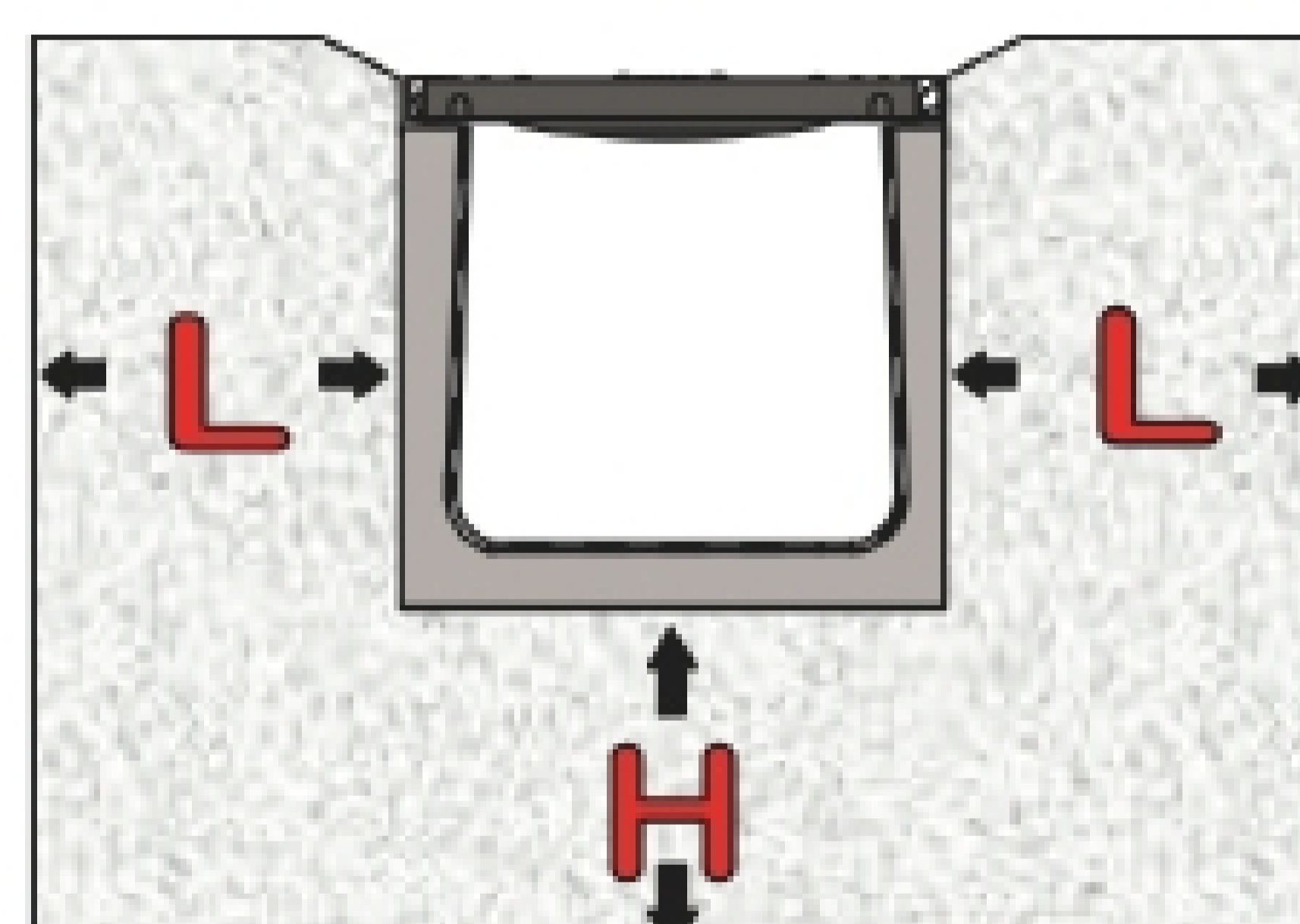

Dimensions							
Load Class		Class A	Class B	Class C	Class D	Class E	Class F
Concrete Bed Size	H	100 mm	100 mm	150 mm	150 mm	200 mm	200 mm
Concrete Lateral Backfill Size	L	100 mm	100 mm	150 mm	150 mm	200 mm	200 mm